

STRAIGHT MALE JACK CRIMP TYPE

CABLE 6/125 S PACK500

R197.134.A24

Series : SMB CARLOCK

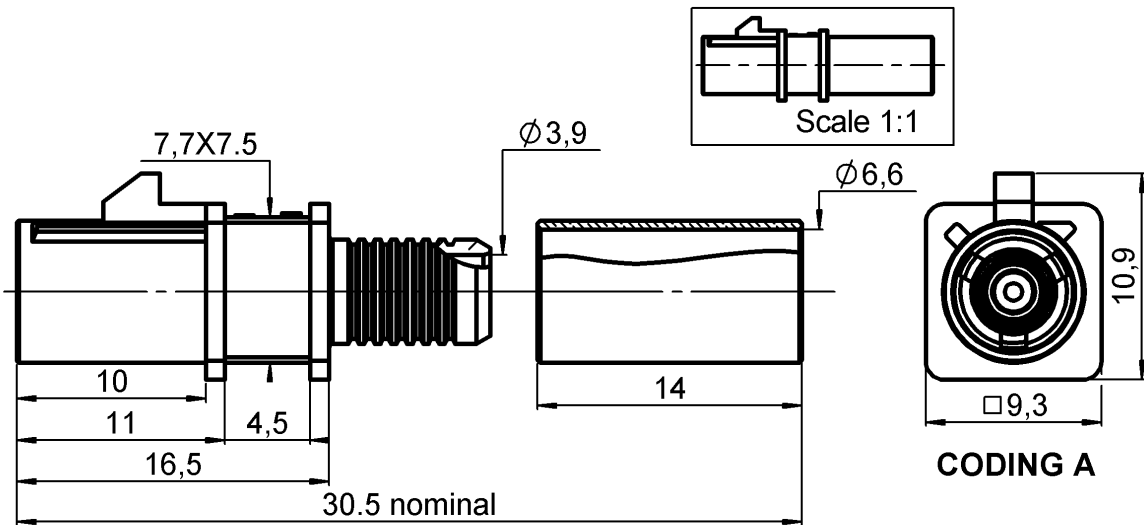

Stamped and formed center contact to be ordered and delivered separately P/N : 250.56.192 rev B

- Tape & reel packaging by 10000
- Diameter of the reel: 600 mm
- Pitch between contacts: 5 mm
- Plating for contact area :Gold 0.5 over Nickel2
- Plating for crimp area :Tin 1 over Nickel 2

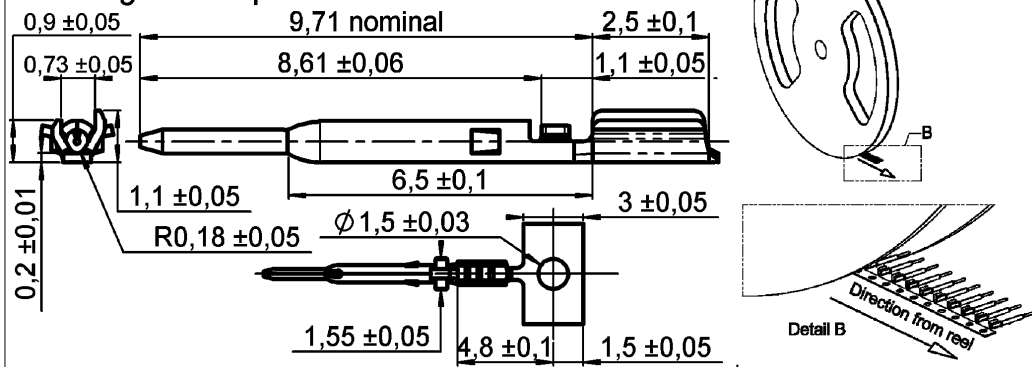

All dimensions are in mm.



COMPONENTS	MATERIALS	PLATING (µm)	
BODY	BRASS	NICKEL 2	
CENTER CONTACT	BRONZE	SELECTIVE GOLD+ SELECTIVE TIN	
OUTER CONTACT	-	-	
INSULATOR	TPX	-	
GASKET	-	-	
OTHERS PARTS	BRASS	NICKEL 2	
-	-	-	
-	-	-	
HOUSING	PA6.6 GF15 (POLYAMIDE)	UL CLASSIFICATION	COLOR
		UL 94 V-2	BLACK RAL 9005

Issue : 0637 C

In the effort to improve our products, we reserve the right to make changes judged to be necessary.



STRAIGHT MALE JACK CRIMP TYPE

R197.134.A24

CABLE 6/125 S PACK500

Series : **SMB CARLOCK**

PACKAGING

Standard	Unit	Other
500	'W' option	Contact us

SPECIFICATION

SAE/USCAR-17 Rev.1 (October 2002)
SAE/USCAR-2 Rev.3 (February 2001)
SAE/USCAR-18 Rev.2 (January 2003)

CABLE ASSEMBLY

ELECTRICAL CHARACTERISTICS

Stripping	a	b	c	d	e	f
mm	3,60	8,50	14,6	0,00	11,0	0,00

Impedance		50	Ω
Frequency		TBD	GHz
VSWR	NA +	0,0000	x F(GHz) Maxi
Insertion loss		NA	\sqrt{F} (GHz) dB Maxi
RF leakage	- (NA		- F(GHz)) dB Maxi
Voltage rating		335	Veff Maxi
Dielectric withstanding voltage		1000	Veff mini
Insulation resistance		1000	M Ω mini

Assembly instruction : **See Pages 3 & 4**

Recommended cable(s)

- RG62/U Modified Foam TFC/Amphenol
Part number T62N94C-VB/LF
- RG62/U Modified Foam Commscope
Part number AMC-62

Characteristics indicated on this data sheet are those that can be achieved with the highest performance cable. Intrinsic limitations of the cable may diminish the performance of the assembly

Cable retention

- pull off **150** N mini
- torque **NA** N.cm

MECHANICAL CHARACTERISTICS

TOOLING

Center contact retention			
Axial force – Mating end		10	N mini
Axial force – Opposite end		10	N mini
Torque		NA	N.cm mini

Part Number	Description	Hexagon
.	.	.
R282.293.000	CRIMPING TOOL	
R282.235.013	CRIMPING DIES	Hex 6.48
R282.223.000	CRIMPING TOOL	Hex 6.48

Recommended torque			
Mating		NA	N.cm
Panel nut		NA	N.cm
Clamp nut		NA	N.cm
A/F clamp nut		0,0000	mm

Mating life		25	Cycles mini
Weight		3,7200	g

OTHER CHARACTERISTICS

* Depends on the cable used.

ENVIRONMENTAL

Operating temperature		-40/+90*	$^{\circ}$ C
Hermetic seal		NA	Atm.cm3/s
Panel leakage		NA	

Issue : **0637 C**

In the effort to improve our products, we reserve the right to make changes judged to be necessary.



STRAIGHT MALE JACK CRIMP TYPE

R197.134.A24

CABLE 6/125 S PACK500

Series : SMB CARLOCK

RECOMMENDED MOUNTING PROCEDURE

1

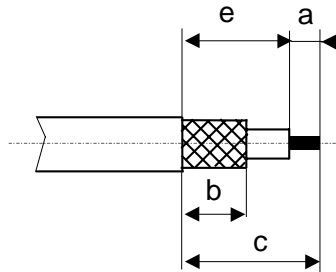

a : inner conductor stripping dimension.
b : braid stripping dimension.
c : jacket stripping dimension.
e : dielectric stripping dimension.

• Strip the cable

2

• Crimp the centre contact with crimping dies as described ,using standard mini applicator.

• check the crimping height $B=0.75\pm0.02$ and the crimping width $A=0.80$ of the center contact.

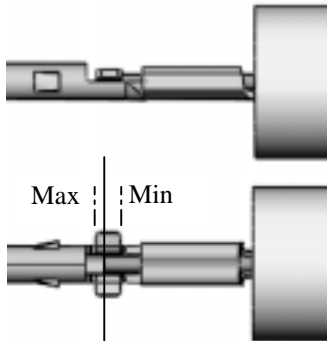
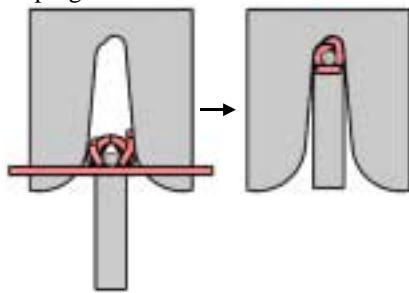

Max
Min

Visual checking

The tip of the cable conductor must be within the width of the positive stop tap.

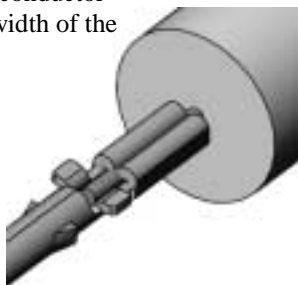

Crimping width

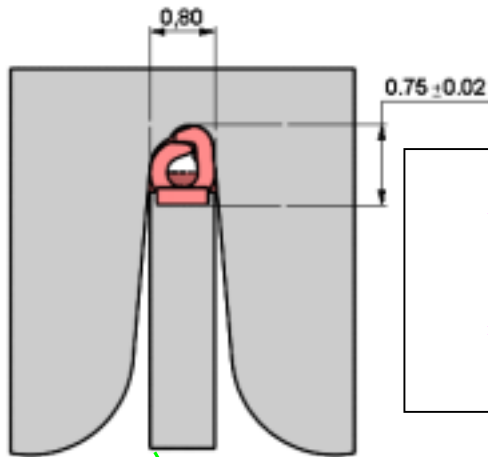

O-Crimp

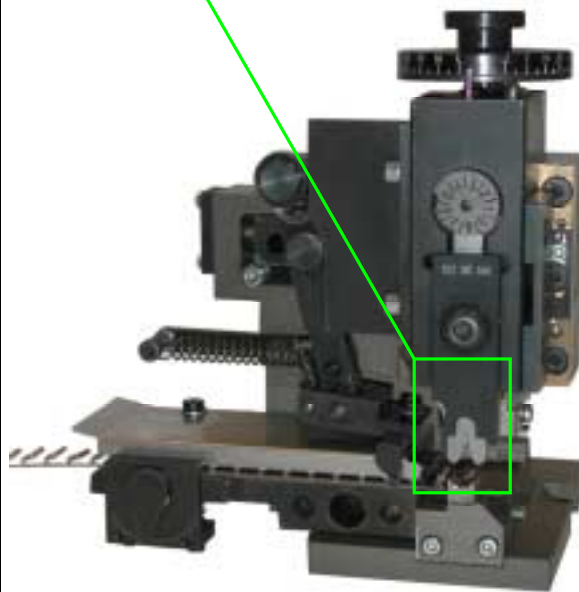

Mini applicator

Issue : 0637 C

In the effort to improve our products, we reserve the right to make changes judged to be necessary.





STRAIGHT MALE JACK CRIMP TYPE

R197.134.A24

CABLE 6/125 S PACK500

Series : SMB CARLOCK

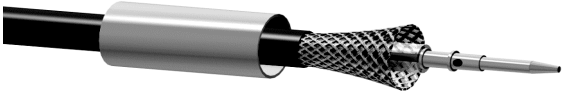
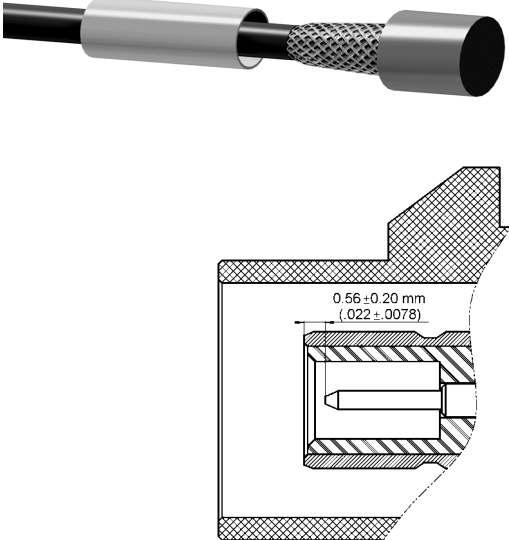
RECOMMENDED MOUNTING PROCEDURE

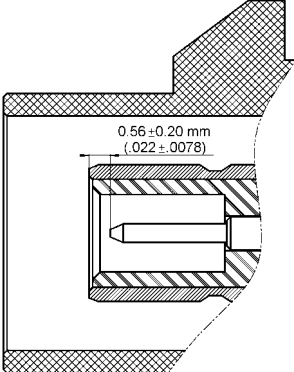
<p>3</p> <ul style="list-style-type: none"> • Slide the ferrule • Fan the braid 	
<p>4</p> <ul style="list-style-type: none"> • Insert gently the center contact into the insulator ; Be cautious you must feel first a force detente corresponding to the center contact barb insertion, and a second force stage corresponding to the center contact reaching its final location. Do not apply an excessive force on the center contact in order to avoid bad interface. A correct insertion force must lead to the interface dimension compliance. • Check the position of the center contact between the top of the insulator and the top of the center contact : 0.56 ± 0.2. 	
<p>5</p> <ul style="list-style-type: none"> • Slide the ferrule over the braid • Crimp the ferrule (Hex 6.48) with crimping tool R282.223.000 or crimping tool R282.293.000 (M22520/5-01) + dies R282.235.013 (M22520/5-13). 	
<p>6</p> <ul style="list-style-type: none"> • Check the position of the center contact between the top of the body and the top of the center contact : 0.56 ± 0.20. 	

Issue : 0637 C

In the effort to improve our products, we reserve the right to make changes judged to be necessary.

